

fissaggio inferiore cabina

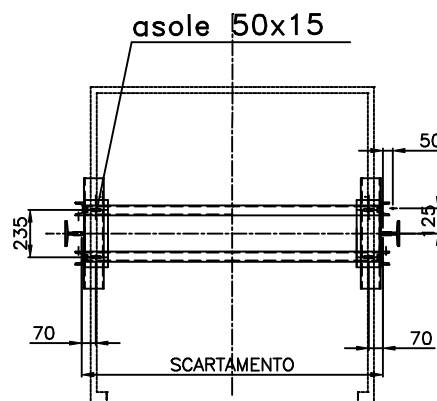

fissaggio superiore cabina

D.T.G.	Q max	Peso arcata	n° FUNI	GUIDE
1550	3500	600	6	Sp 16

Q= PESO ARCATA + PESO CABINA + PORTATA

PEZZO	Q.TA'	SEZ. PROFILI
1	04	30x65x160x65x30 sp 5 mm
2	02	40x140x240x140x40 sp 5mm
3	04	UNP 65X42
4	02	C30x65x260x65x30 sp 5mm
5	04	PIATTO 60X6

ARCADE IN TAGLIA "TIPO C"

Paracadute progressivo pc30da

Velocità max impianto 1,60m/sec

