

fissaggio inferiore cabina

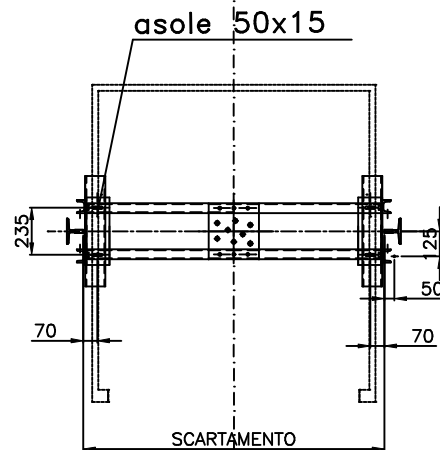

fissaggio superiore cabina

D.T.G.	Q max	Peso arcata	n° FUNI	GUIDE
1550	3500	350	6/8	Sp 16
Q= PESO ARCATA + PESO CABINA + PORTATA				

ARCATA TIRO DIRETTO "TIPO C"
 Paracadute progressivo pc30da
 Velocità max impianto 1,60 m/s

PEZZO	Q.TA'	SEZ. PROFILI
1	04	45X50X180X50X45 sp 5 mm
2	02	40x140x260x140x40 sp 5mm
3	04	UNP 65X42
4	02	C30x65x260x65x30 sp 5mm
5	04	PIATTO 60X6

