

F - FONDO CABINA
 A - ALTEZZA MONTANTE
 H - ALTEZZA CABINA COMPRESO DI FONDO
 D - INTERASSE PATTINI
 P - PROFONDITA' CABINA
 L - LARGHEZZA ESTERNA CABINA

ARCATA IDRAULICA IN TAGLIA A 2 PISTONI

PORTATA Q=6000 Kg.

Paracadute istantaneo

Velocità max 0,63 m/sec

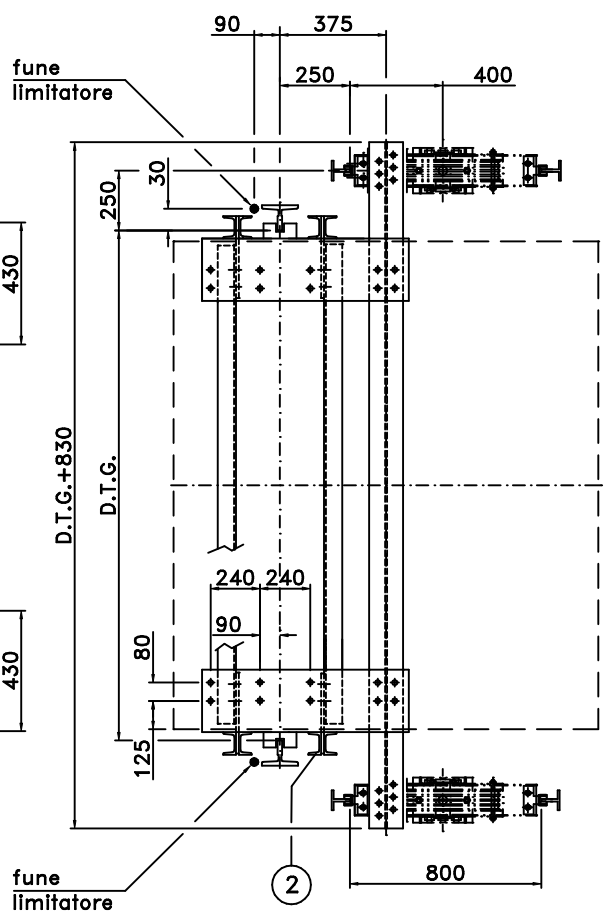
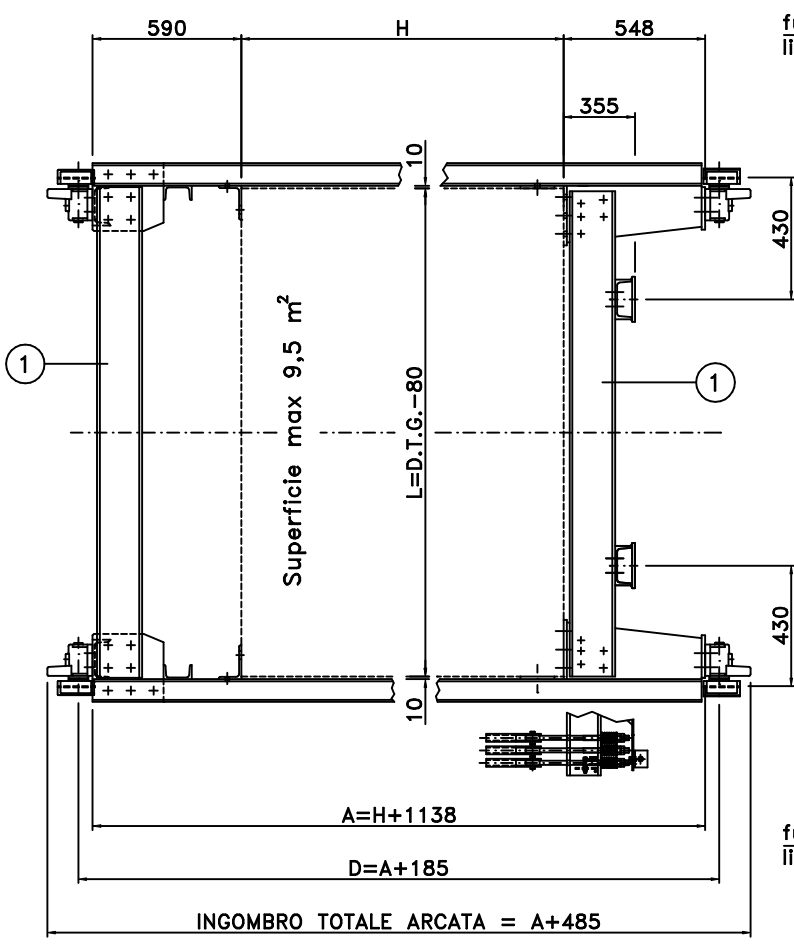
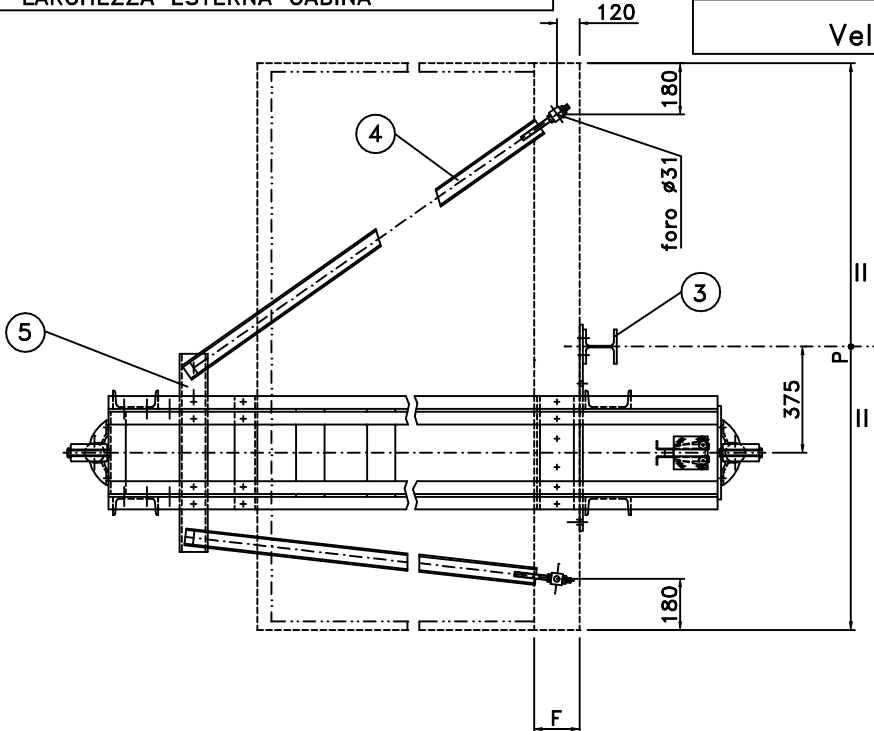

PEZZO	Q.TA'	SEZ.	PROFILI
1	04	L	UNP 200
2	08	L	UNP 100
3	01	I	HEB 160
4	04	L	UNP 100
5	02	L	UNP 140
6			

