

fissaggio superiore cabina

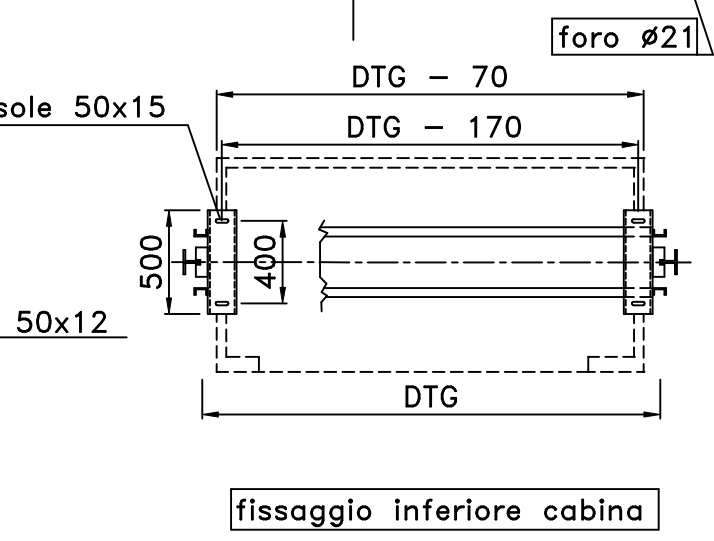

fissaggio inferiore cabina

D.T.G.	Q max	Peso arcata	n° FUNI	GUIDE
1500	3500	270	4-5-6	Sp 16
1600	3300	280		
1700	3100	290		
1800	2900	300		

Q= PESO ARCATA + PESO CABINA + PORTATA

ARCATE DIRETTE A FUNI"TIPO C"  
 Paracadute istantaneo PI 30  
 Velocità max 0,63 m/sec

PEZZO	Q.TA'	SEZ. PROFILI
1	04	25x50x180x50x25 sp 4mm
2	02	40x100x260x100x40 sp 5mm
3	04	UNP 65
4	02	40x100x260x100x40 sp 5mm
5	04	UNP 60

