

car top fixing

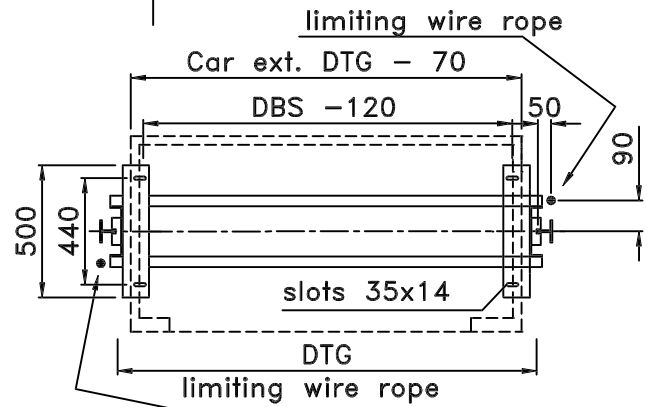

car lower fixing

D.T.G.	Max Q	CAR FRAME WEIGHT	No. ROPES	CAR GUIDES THICKNESS
850	1600	95	3 / 4	8 mm 9 mm 16 mm
900				
950				
1000	1500	100		
1050				
1100				
1150	1400	105		
1200				
1250	1300	105		
1300				
Q= CAR FRAME WEIGHT + CAR WEIGHT + LOAD				
ELEMENT	Q.TY	PROFILES SECTION		
1	04	20x50x140x50x20 th. 3mm		
2	02	47x150x47 th. 3mm		
3	02	50x60x70 th. 5mm		
4	02	60x60 th. 5mm		

TRACTION CAR FRAME "TYPE A"

Instantaneous safety gear PI 30

Max speed 0,63 m/sec

